

# FTG600GL PARTS

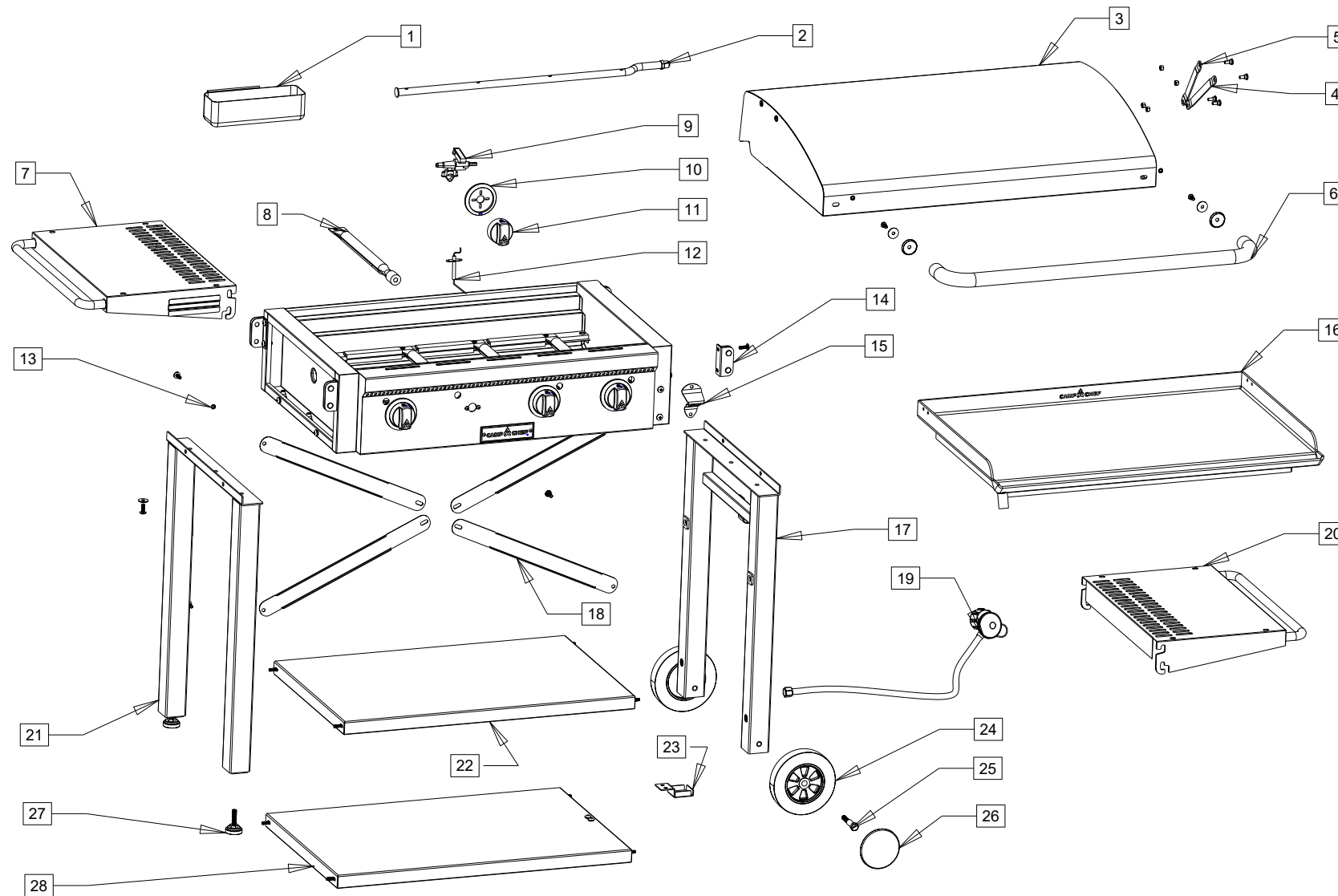

Item	Description	SKU Number	Qty
1	Griddle Grease Cup	FTG600-10	1
2	Manifold	FTG600-5	1
3	Lid	FTG600GL-1	1
4	Lever A (Longer)	FTG600GL-2	2
5	Lever B (Shorter)	FTG600GL-3	2
6	Lid Handle	BB60-3	1
7	Shelf Left	FTG600-3	1
8	Burner	FTG600-8	4
9	Valve	FTG600-6	4
10	Bezel	FTG600-27	4
11	Knob	CCH3-2	4
12	Igniter	FTG600-9	4
13	Hardware Kit	FTG600GL-4	1
14	Shelf Bracket	CCH-6	4
15	PG Bottle Opener	BTOP	1
16	GRIDDLE	SG600	1
17	Leg Right	FTG600-28	1
18	Rear Leg Brace	FTG600-31	4
19	Regulator	HRL	1
20	Shelf Right	FTG600-4	1
21	Leg Left	FTG600-29	1
22	Upper Shelf	FTG600-32	1
23	Tank Bracket	FTG600-23	1
24	Cart Wheel	CCH-25	2
25	Axle Bolt	FTG600-20	2
26	Cart Wheel Cap	CCH-27	2
27	Leveling Foot	FTG600-17	2
28	Lower Shelf	FTG600-12	1

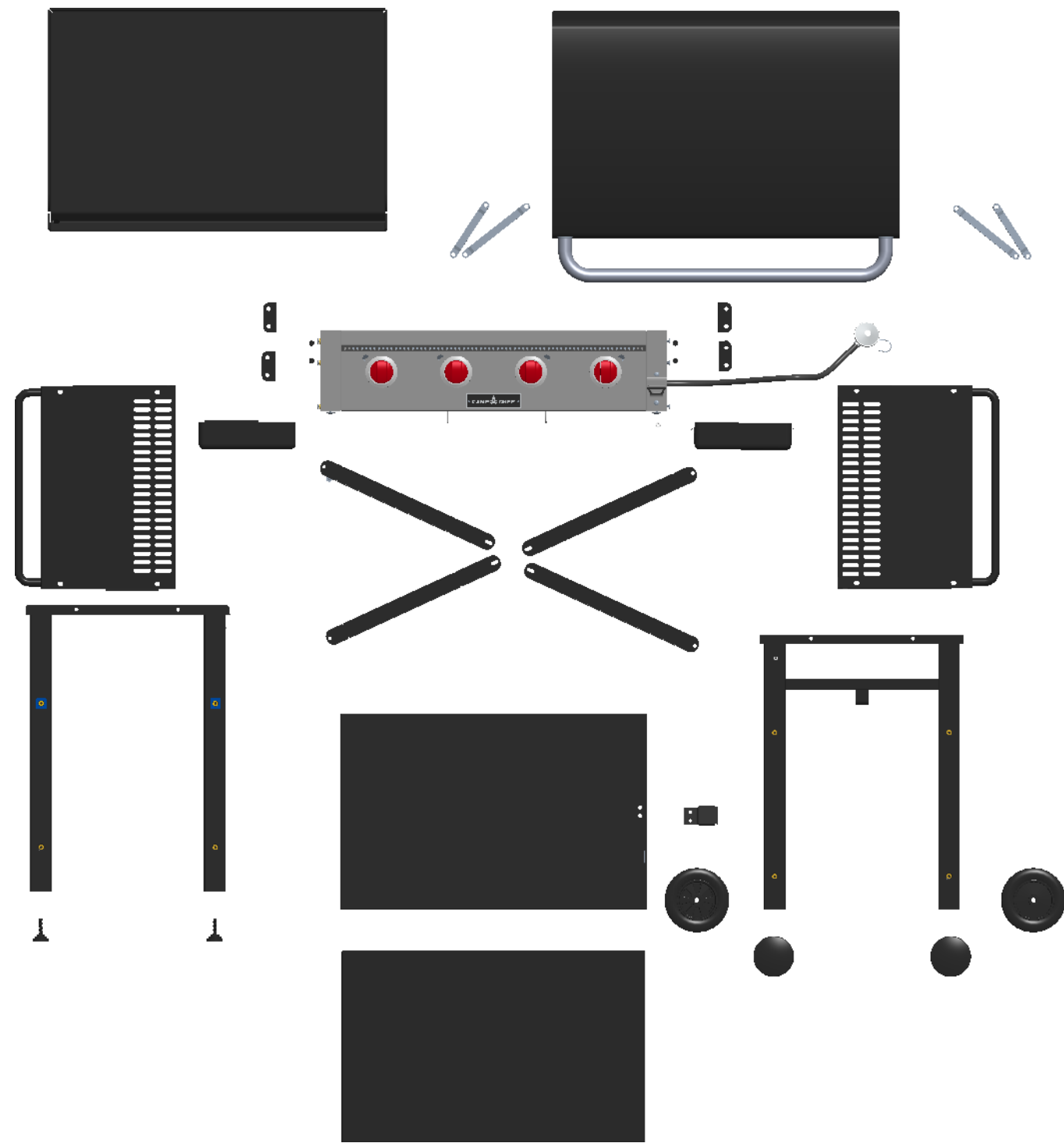

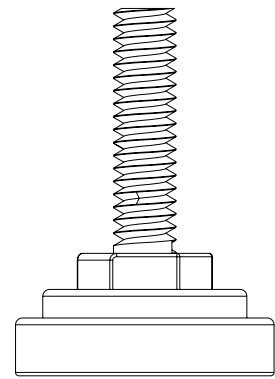

FTG600-12  
(Foot)

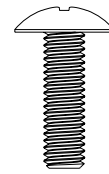

M6 X 20 Bolt

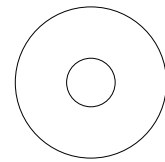

M6 Washer

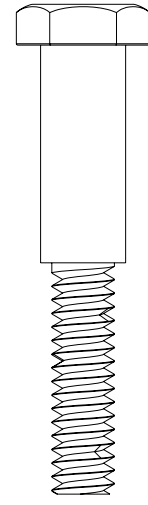

FTG600-20  
(Axle Bolt)

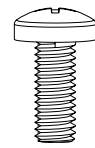

M6 X 15



M6 Lock Washer

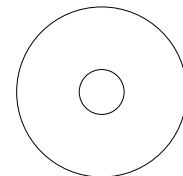

M6 Large Washer

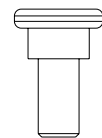

M6 X 15



M6 Hex Lock Nut

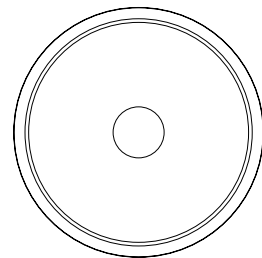

Handle bezel

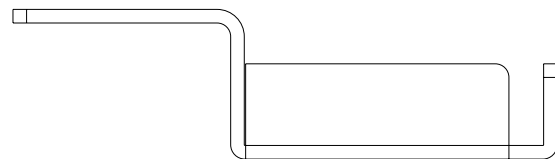

Tank holder bracket



HINGE FRONT "A"



HINGE BACK "B"

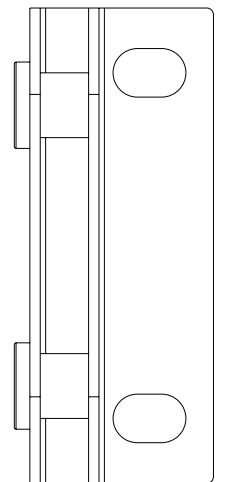

Shelf brackets

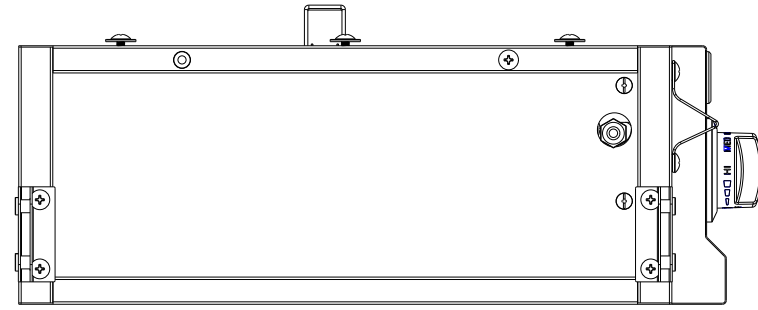
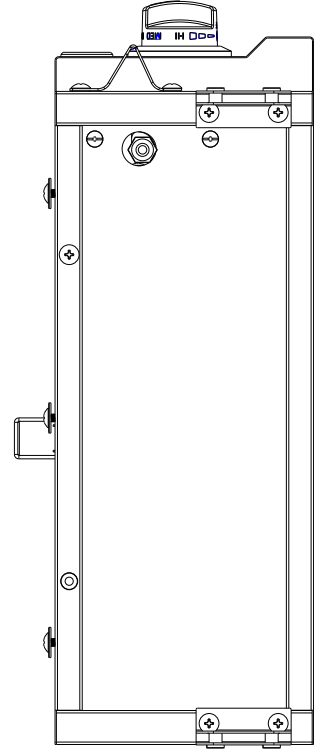

NOTES: □  
M6 X 20 BOLT (10) □  
M6 WASHER (6)

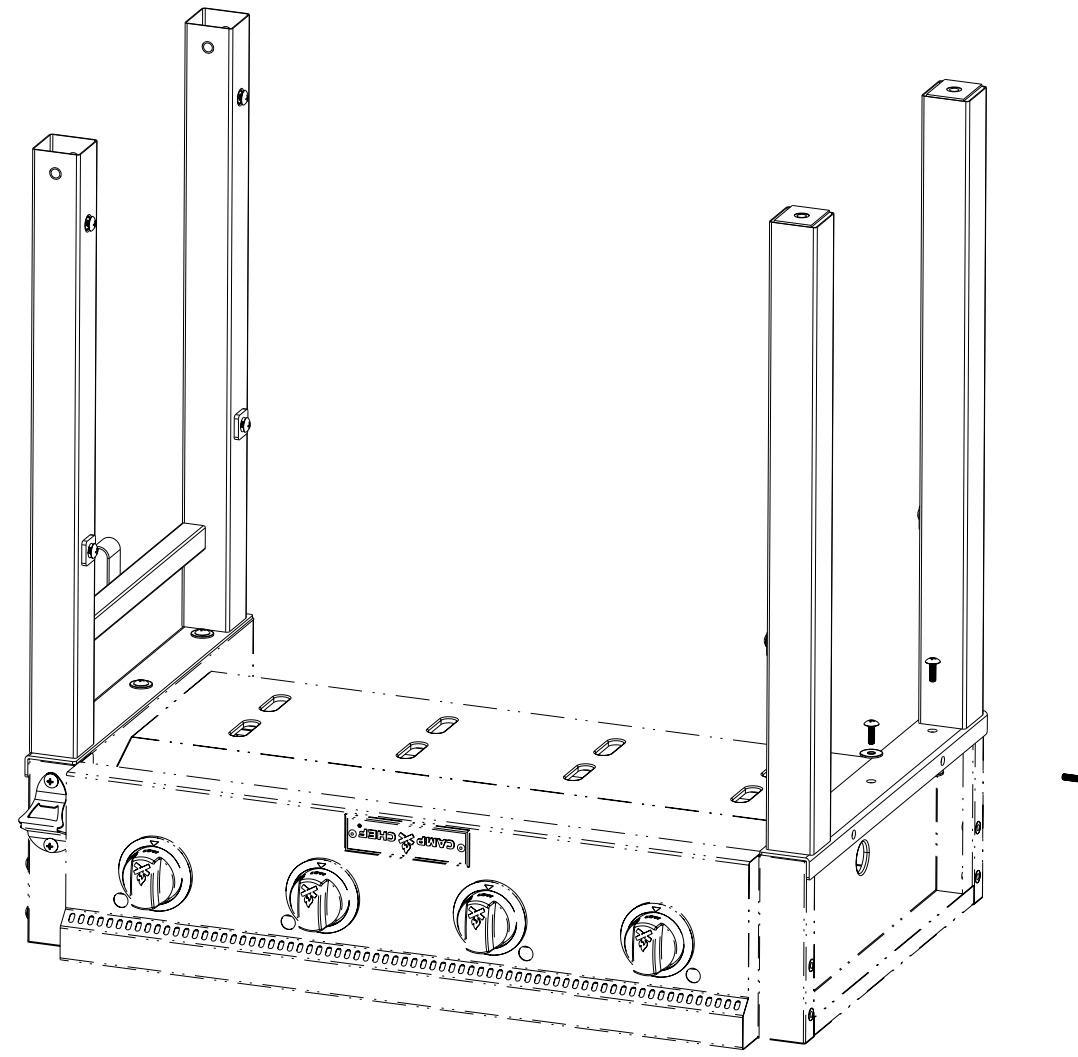

NOTES: □  
M6 X 20 BOLTS (10)

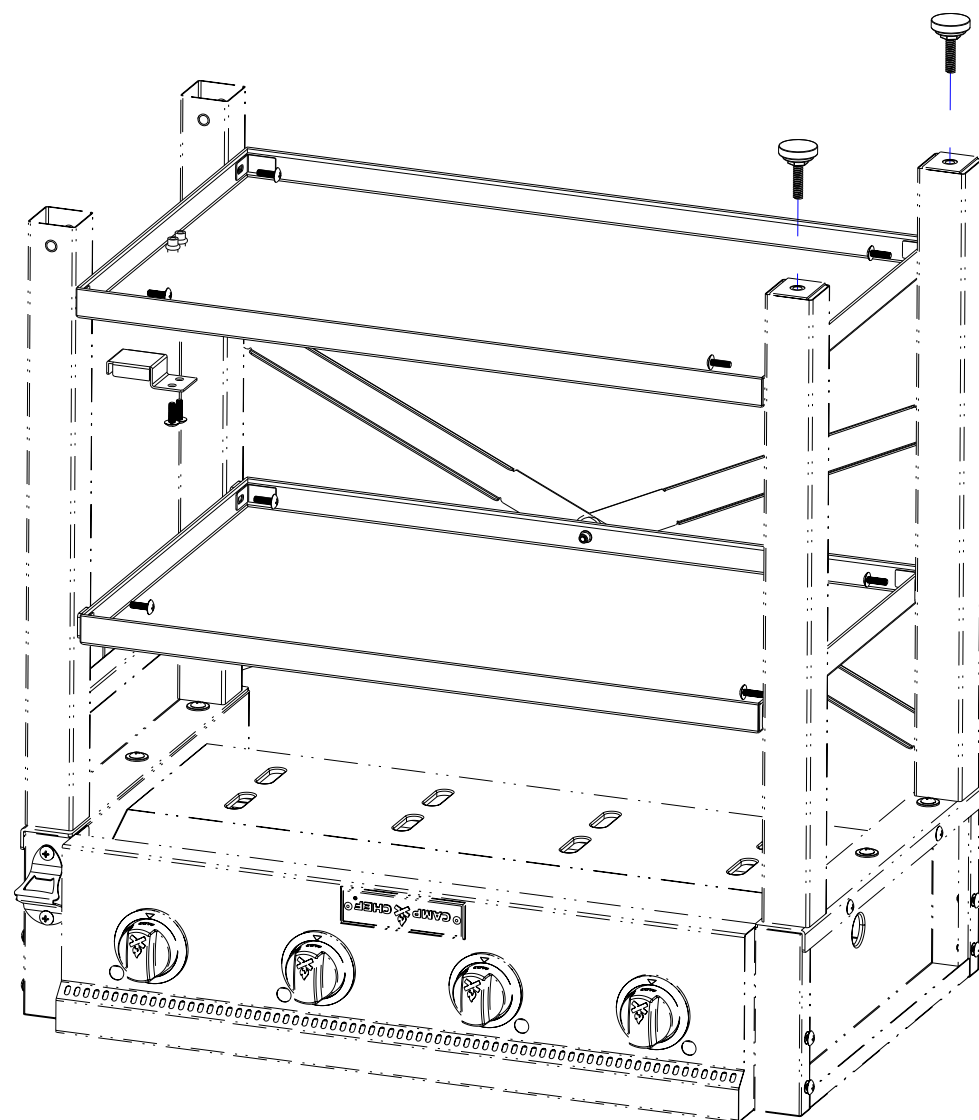

NOTES: □  
AXLE BOLT FTG600-20

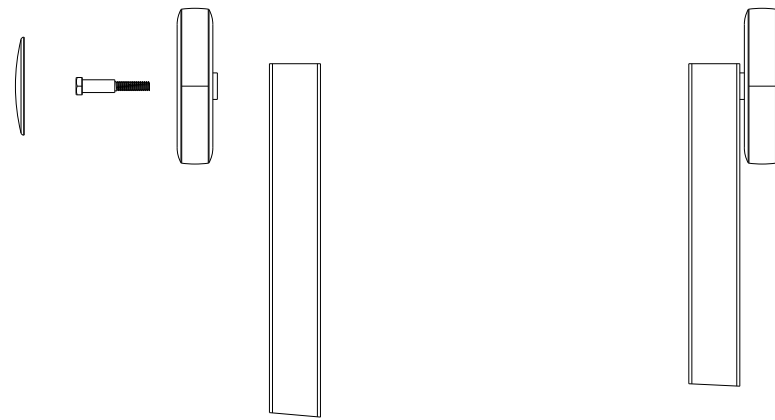

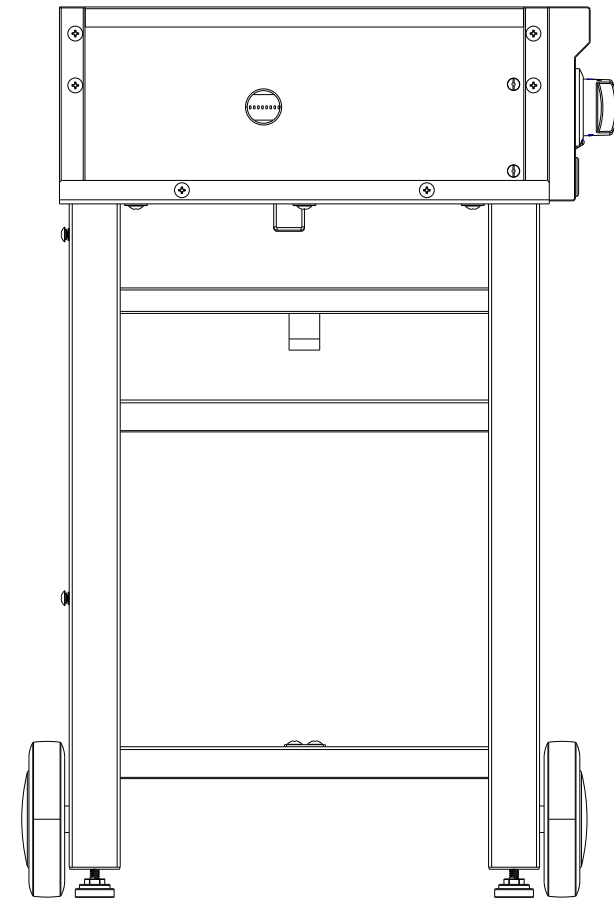
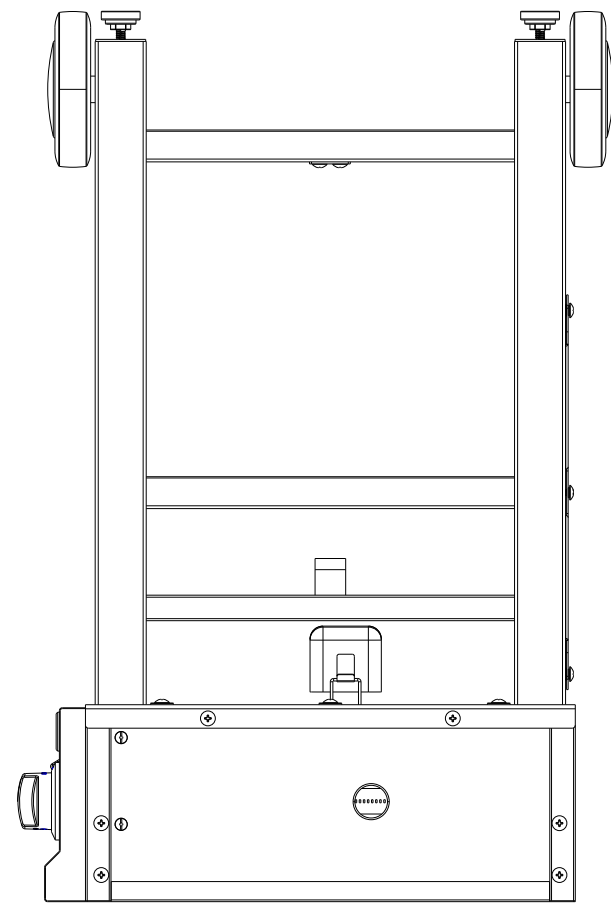

Notes: □  
M6 LOCK WASHER (5) □  
M6 X 20 BOLTS (5)

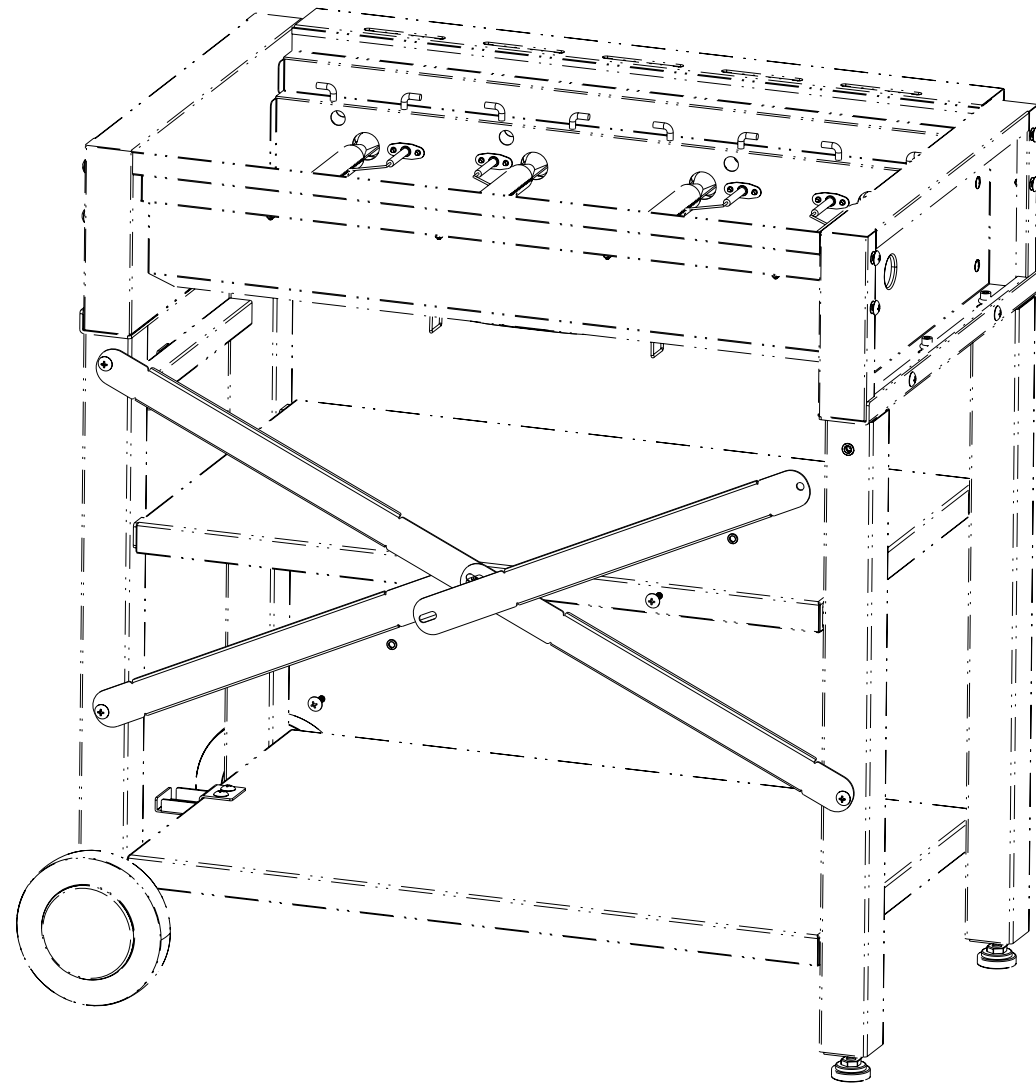

NOTES: □  
M6 X 20 BOLTS (8)

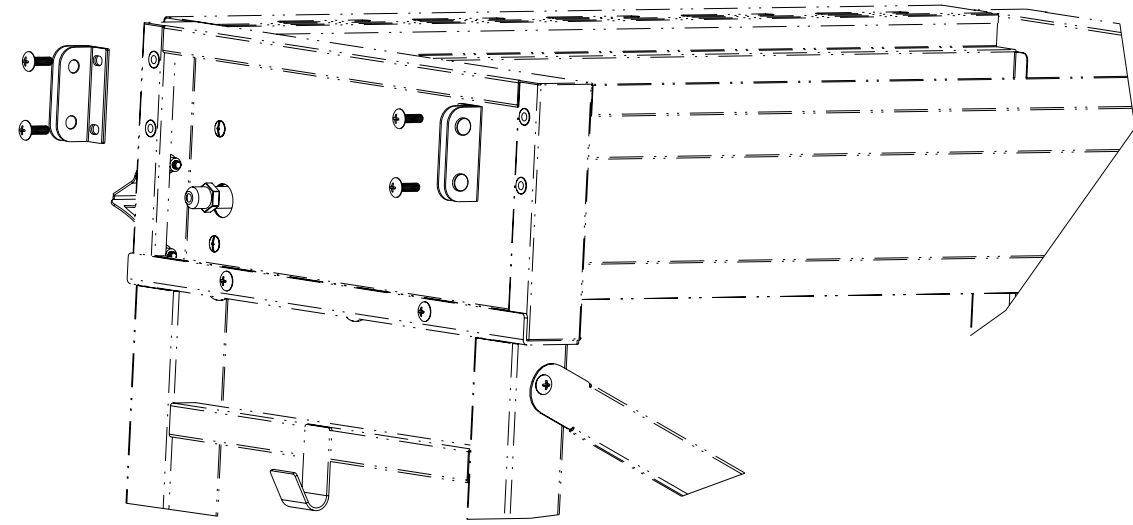

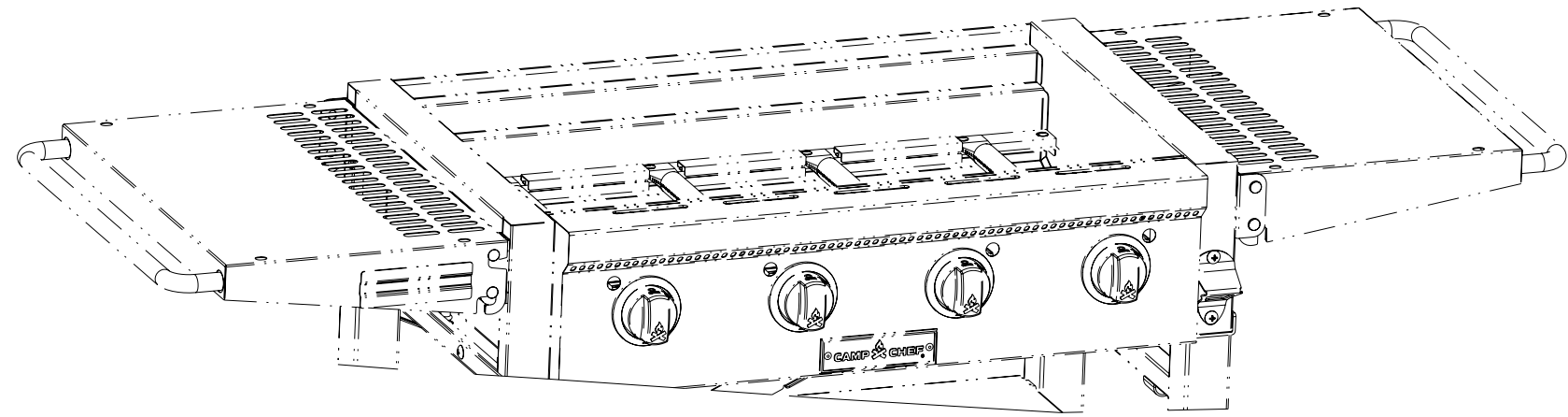
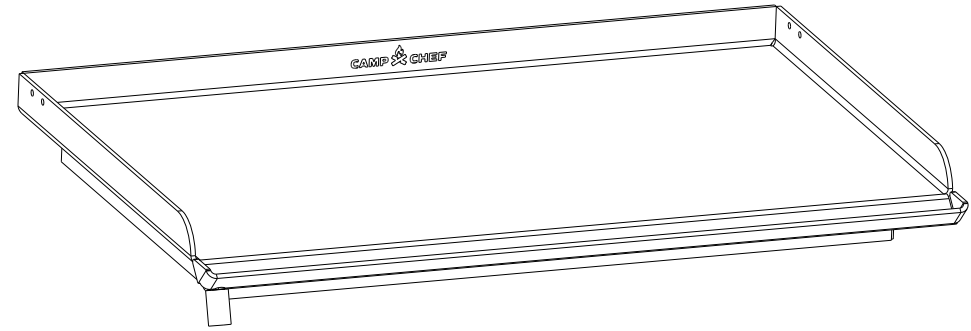

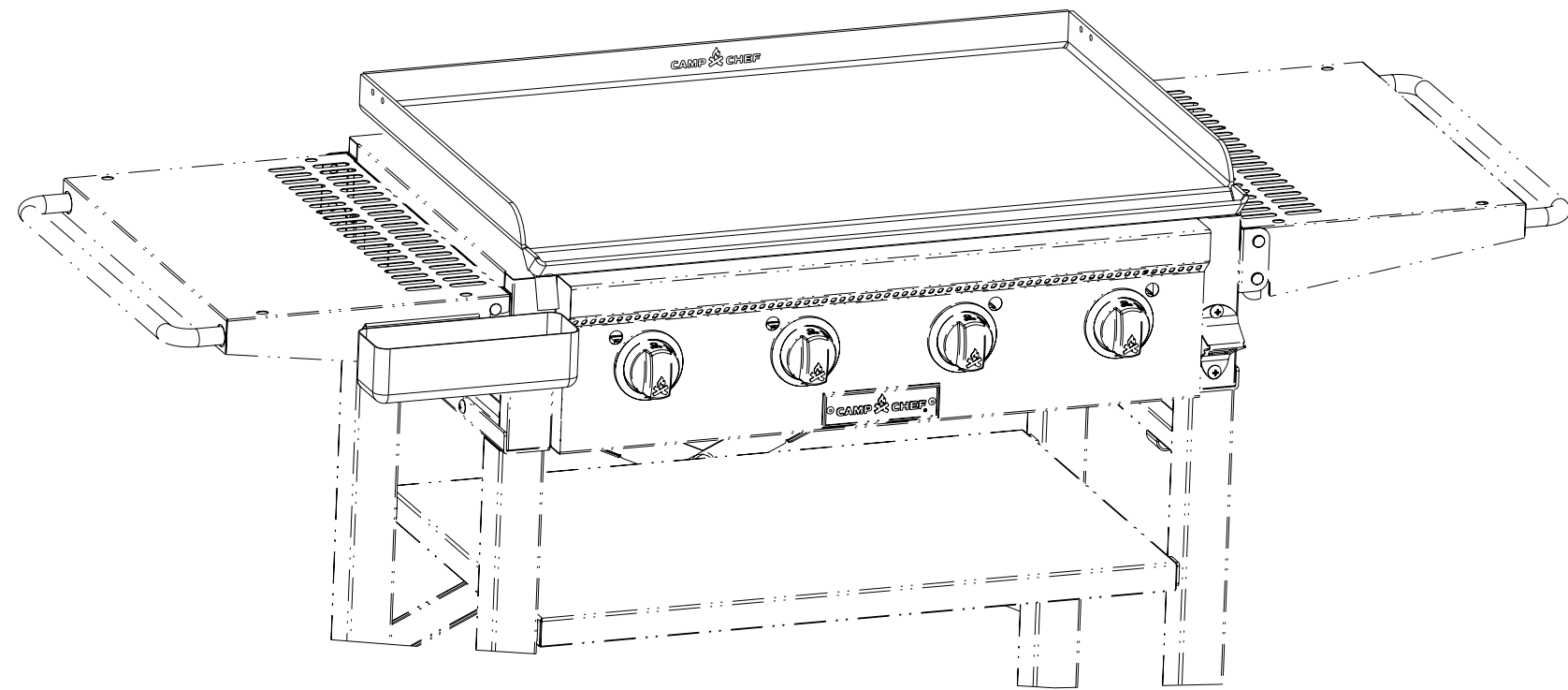

Notes: □  
M6 X 15 Bolt □  
M6 Hex Lock Nut □

SEE DETAIL A

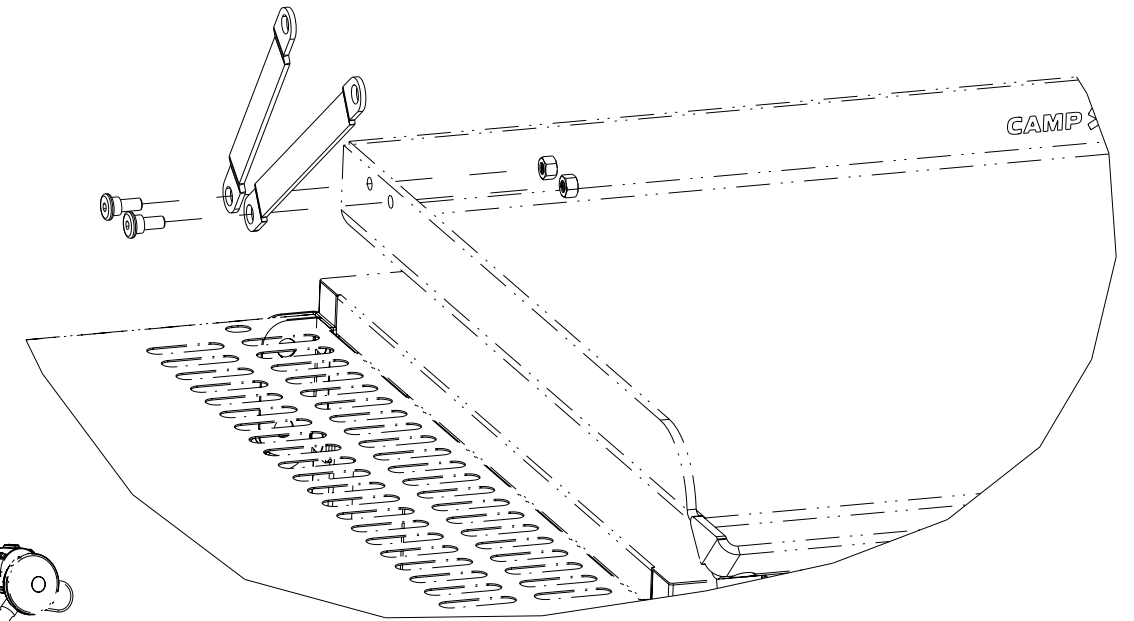
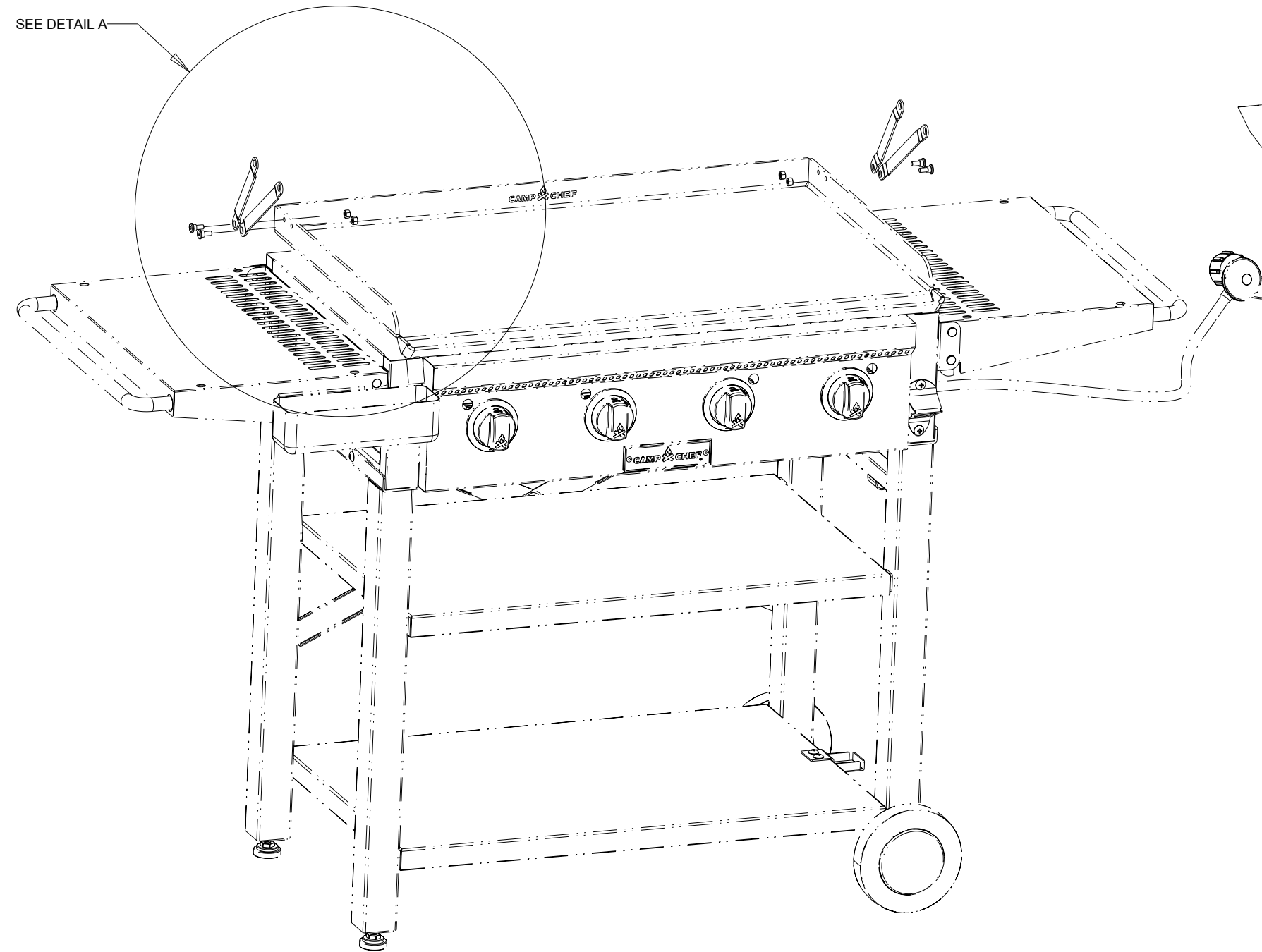

DETAIL A  
SCALE 0.300

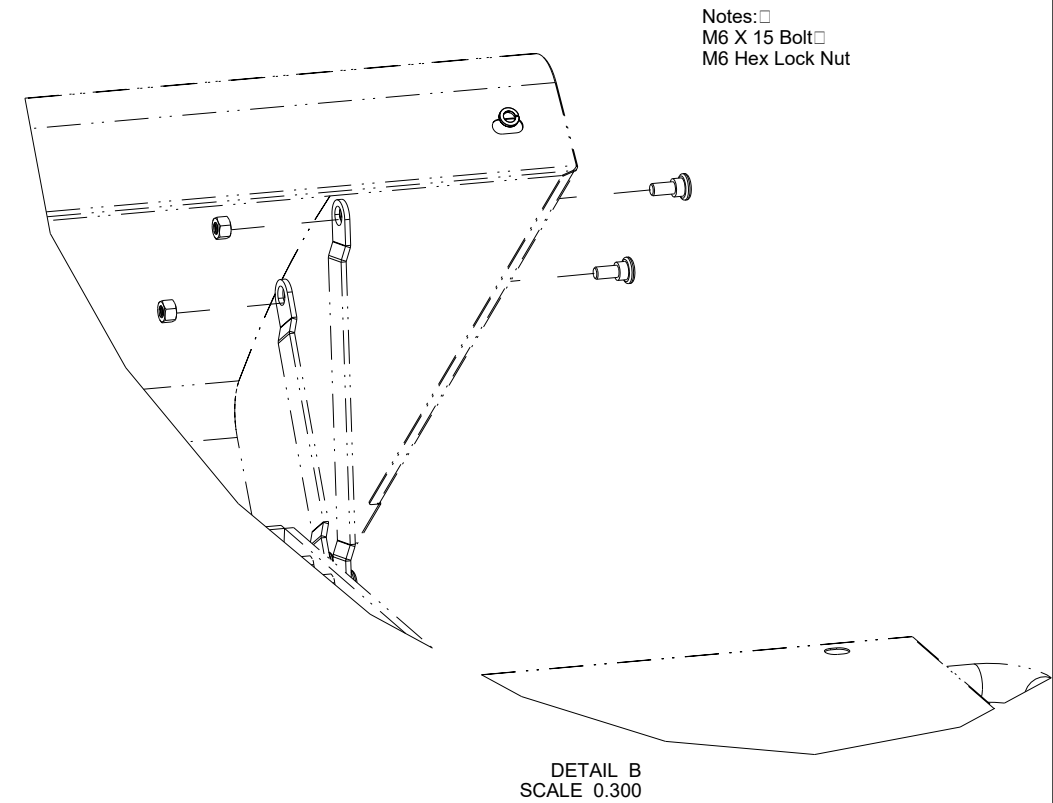
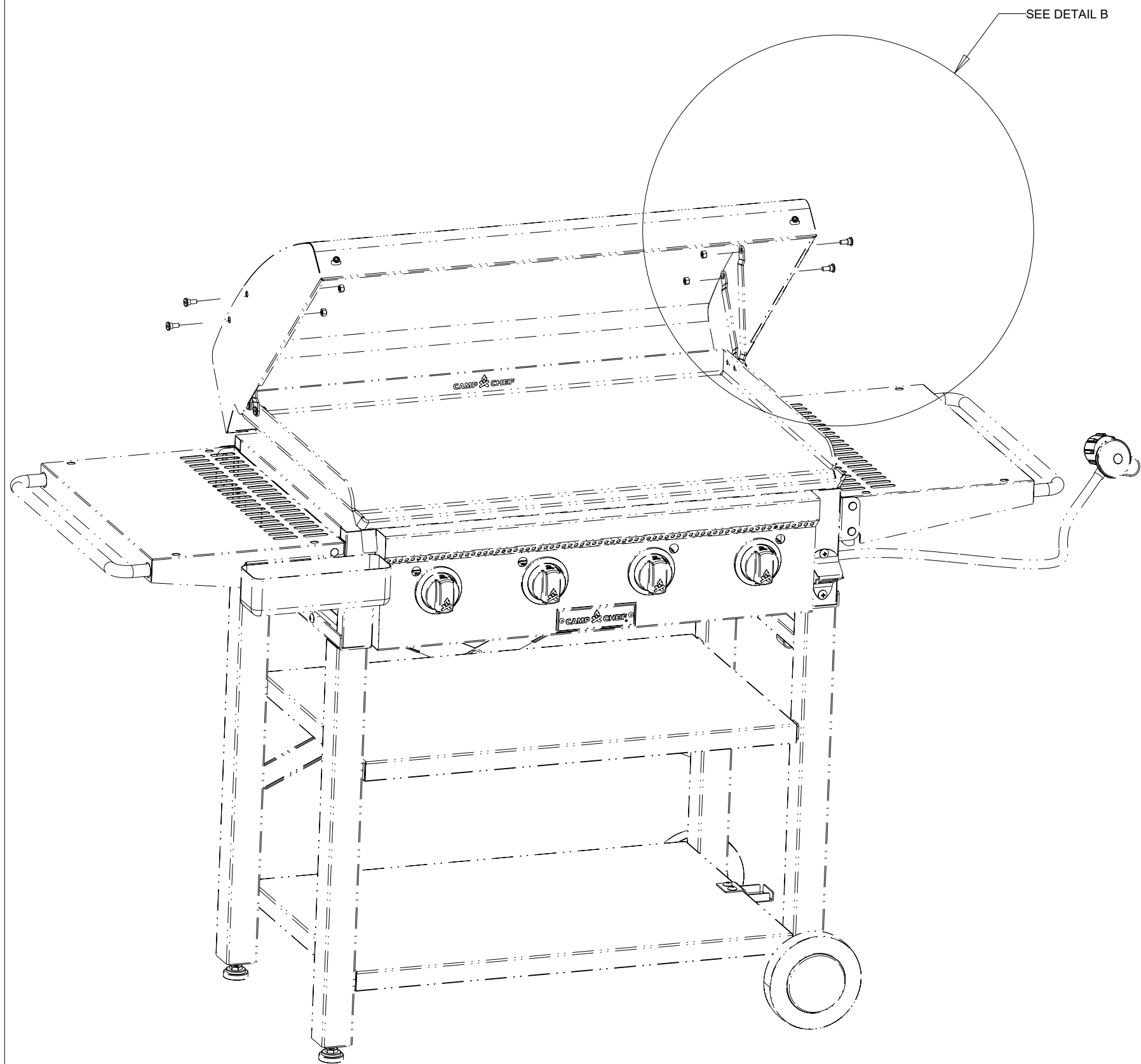

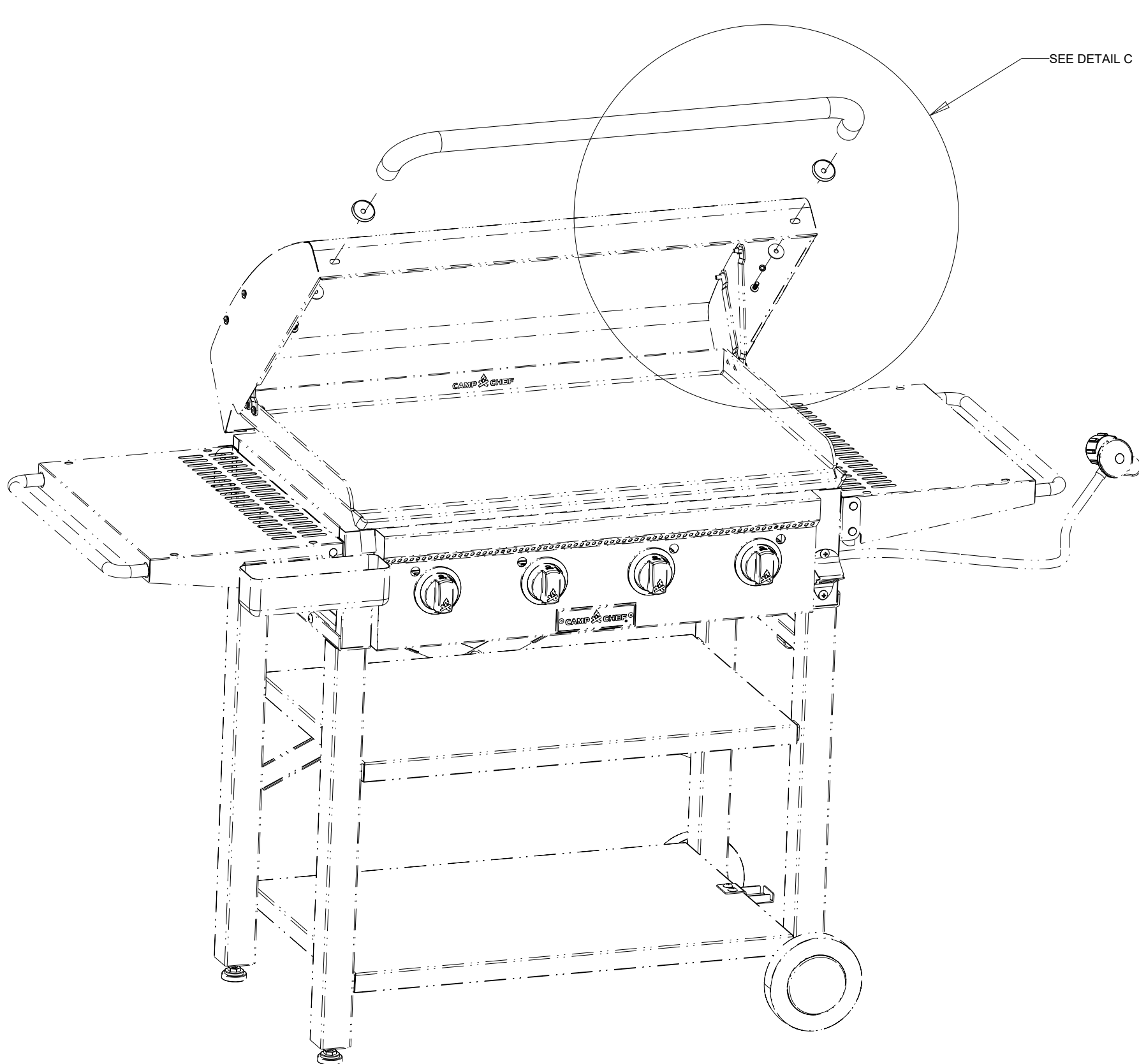

SCALE 0.150

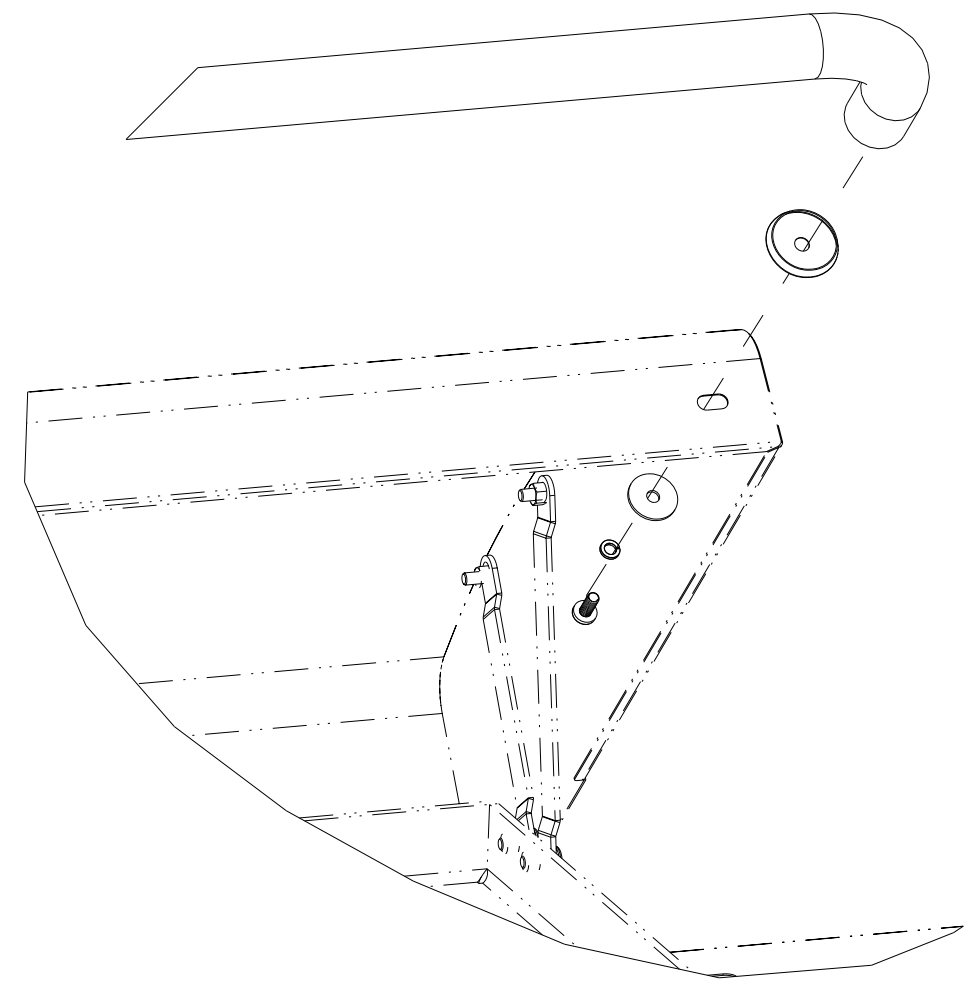

DETAIL C  
SCALE 0.300

